

Amplitude-phase keying (APK)

In M-ary PSK only the phase of the signal carries any information.

Amplitude-phase keying (APK) is an alternative where *both* amplitude and phase are used in the modulation. Less power is required for APK than for MPSK, but the system does become more complicated.

Two possible signal constellation diagrams for 16-ary APK are shown below:

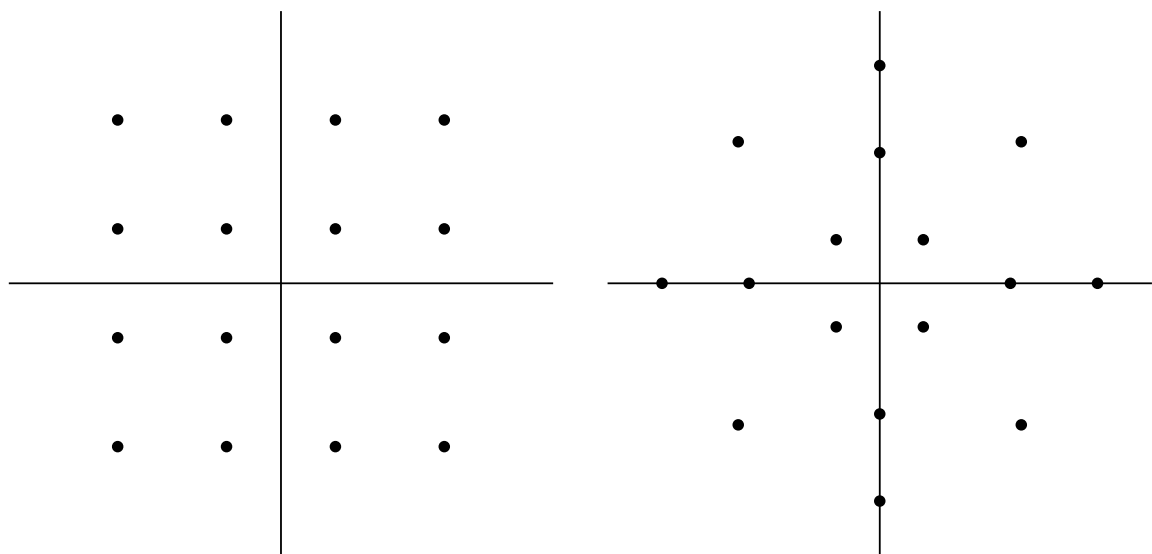

The first uses three different amplitudes, two with four phases and one with eight. The second uses four amplitudes and four phases.

The general APK signal is

$$s(t) = x(t) \cos \omega_c t + y(t) \sin \omega_c t,$$

where

$$g(t) = x(t) + jy(t) = R(t)e^{j\theta(t)}.$$

In the case of the first constellation diagram above, $x(t)$ and $y(t)$ are each permitted to have four levels per dimension. The 16-symbol signal may be generated using a system of the following form:

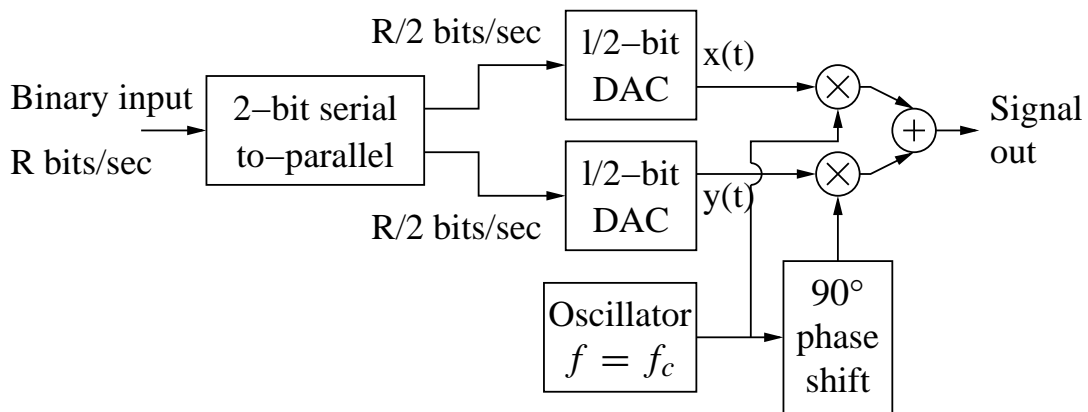

In general, APK can be generated using binary-to- L -level converters in each of the I and Q signal paths in a QPSK modulator, with $L = \sqrt{M}$. In this sense APK is M -ary QAM. For example, symbols corresponding to the first constellation diagram above can be generated using two-to-four level converters in a QPSK system. Since the total symbol rate is reduced by a factor of four, the potential bandwidth efficiency of such a system is 4 bps/Hz. In general the spectral efficiency for rectangular pulses is

$$\eta = \log_2 M \text{ bps/Hz.}$$

A block diagram for demodulating using in-phase and quadrature detection is shown below:

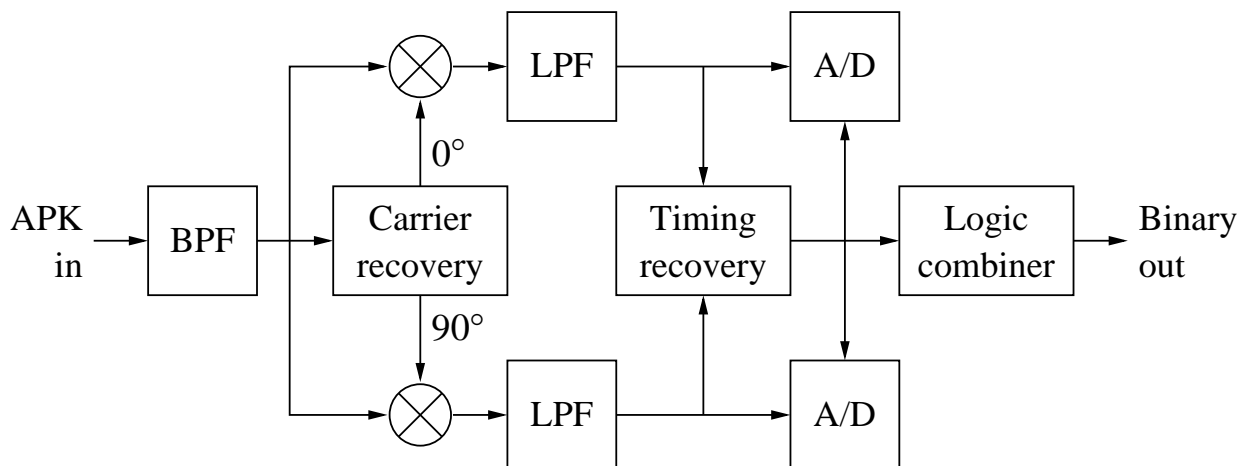

Plots of the probability of error performance for APK are shown in Stremler.

Note that 8-ary APK systems require about 1 dB less power than 8-ary PSK for the same error rate, but this difference increases to 3.5 dB for the $M = 16$ cases. For large M APK therefore has definite advantages.

Partial response signalling techniques can also be introduced into APK systems. This is called **quadrature partial response signalling** (QPR), and involves using partial response methods in both the I and the Q signal paths. QPR systems have some SNR advantages over PSK systems, and are easily implemented.